

THE TELECOMLINE SERIES

12-00203

Single pair high speed line protector

Features

- Economical single pair protection
- Low residual voltage
- Suitable for high speed networks
- Meets industry standards
- Reduces down time
- Increases network reliability
- 2 year warranty



Application

The Clearline KP1HS series single line protector uses state of the art semiconductor technology to protect telecom systems and networks from the damaging effects of induced lightning, AC induction and electrostatic discharges. In the normal mode of operation, the protection module is transparent to the functioning of the telecommunication system, but when the voltages exceed the breakdown voltages, the semiconductor device activates and diverts the harmful energy away from the equipment being protected.

The single line protectors are designed to interface with Krone LSA Plus disconnect blocks, and together with the earth bars, protect applications at telephone exchanges, remote cellular sites, building entrance terminations and equipment at customer premises.

Specifications

Application	High speed data
Max operating voltage	6VDC
Max operating current	0.3A
Max discharge current 8/20 Differential mode (8/20)	400A
Max discharge current 8/20 Common mode	10kA
Residual voltage at 5kA differential mode	Approx. 170V
Residual voltage at 5kA common mode	Approx. 160V
Series resistance (per leg)	3.3Ω
Data rate	10MHz
Temperature range	0°C to +70°C
Data speed	10MHz
Optional accessory Earth frame - Order code	12-00660

Dimensions

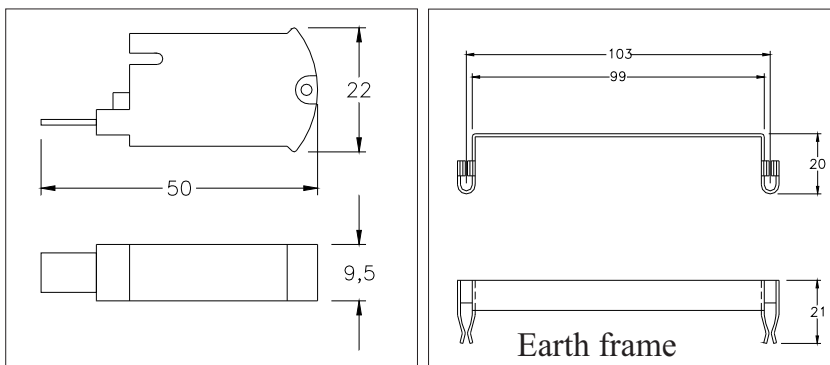

*Krone is LSA plus is registered trademark of Krone GMBH Germany

Circuit Diagram

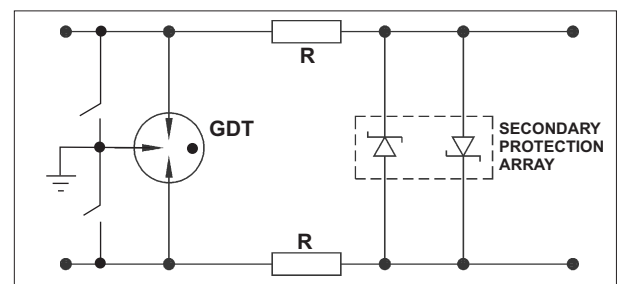

Designed and Manufactured by:

Clearline Protection Systems (Pty) Ltd
 385 Roan Crescent Corporate Park North, Old Pta Road,
 Midrand, South Africa
 P.O. Box 5985, Halfway House, 1685
 Tel: +27 (0) 11 848-1100
 Fax: +27 (0) 11 314-3880
 E-mail: info@clearline.co.za
 www.clearline.co.za

